



Robotics

Packaging Automation Trends: Using Small Assembly Robots in Upstream Packaging Processes

*A Guide for Manufacturers, Packaging Engineers,
Machine Builders and System Integrators*

***With today's
heightened
global
competition,
manufacturers
who do not
increase their
level of
automation may
not survive.***

Manufacturers have always faced the challenge of constantly needing to find new ways to reduce the cost of their packaging processes. In today's globally connected world, however, the game is much tougher and the stakes are much higher.

In order to meet the new challenge of sharply increased global competition, manufacturers are now being forced to cut costs more drastically than ever before. Those who do not succeed in doing so risk not only losing market share, but going out of business entirely.

Inevitably, such cost cutting means automating manual processes and increasing the level of automation of semiautomated processes. It also means re-evaluating current automation solutions in light of newer, more economical technology.

Packaging has traditionally been the realm of fixed automation, often supplemented by manual labor to carry out machine tending and other intermediate process steps, mainly material handling.

For some continuous, high-speed, high-volume processes, fixed automation remains the best solution. Increasingly, however, manufacturers are turning to the use of industrial robots, which offer several advantages over fixed automation.

Using Small Assembly Robots in Upstream Packaging Processes

This paper will examine the benefits of using small assembly robots in upstream packaging processes, that is, those processes that occur prior to final cartoning and palletizing, both of which generally require larger-size robots.

Global Competition Likely to Increase

The globalization of world markets is likely to grow even more in coming years, and at an increasingly faster pace.

As the economies of semideveloped and undeveloped countries continue to emerge, they will almost certainly result in new consumer markets, new sources of low-cost labor—and increased manufacturing competition.

As a result, the pressure on manufacturers to increase their level of automation will most likely continue to grow as well.

The Challenges of Fixed Automation

For manufacturers seeking to cut packaging costs, fixed automation has significant drawbacks.

Throughout most of the twentieth century, propelled by the dynamic growth of the consumer society, packaging benefited greatly from dedicated, fixed-automation machines, which offered previously unachievable scales of economy.

Yet at the same time, fixed automation has drawbacks. Each machine must be specially built to handle a specific product. Furthermore, changing a product's shape or size means expensive new tooling, or even a whole new machine.

There are other drawbacks as well, such as high maintenance and service costs; large, bulky size; and the open mechanical design of many machines, which presents a danger of injury to employees.

Furthermore, the high cost of fixed automation limits its use mainly to high-volume operations with few or no product changes.

Even so, until fairly recently, the advantages of fixed automation outweighed the disadvantages. Manufacturers had a solution that worked, and without the fierce new competition from offshore manufacturing that globalization would bring, there was no compelling reason to do anything differently.

Now, however, the situation has dramatically changed. In order to stay in business, manufacturers must find new, less-costly and more-flexible alternatives to fixed automation.

The Solution: Small Assembly Robots

Small assembly robots can perform both primary and secondary packaging operations.

Fortunately, a class of robot arms often referred to as small assembly robots provides just such an alternative.

Despite their name, assembly robots can carry out a much wider variety of tasks than just assembly. These include all the various material-handling and other functions involved in upstream packaging processes, such as pick and place, loading and unloading, package forming, product insertion, etc., as well as secondary operations such as labeling, testing and inspection.

In terms of size, for the purposes of this paper, small assembly robots are considered to be those with payload capacities up to 20 kg (44 pounds) and reaches up to 1,300 mm (51 inches).

4-Axis SCARA vs. 6-Axis Articulated Robots

Four-axis SCARA robots are especially well-suited for high-speed pick and place; six-axis articulated robots offer added flexibility of movement.

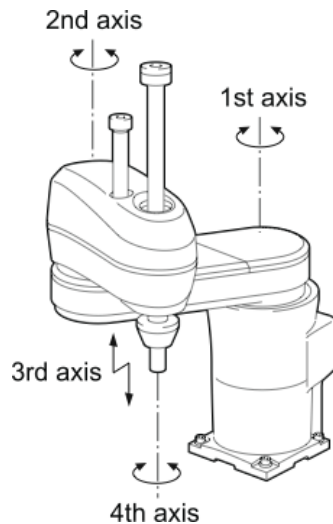

Four-axis SCARA robot.

There are two basic types of assembly robots: four-axis SCARA robots and six-axis articulated robots.

The term “SCARA” stands for “selective compliance articulated robot arm.” This refers to the fact that a SCARA’s arm segments, or links, are “compliant,” that is, they can move freely, but only in a single geometrical plane.

The first two links of a SCARA swivel left and right in the horizontal plane. The third link consists of a metal rod called a quill, which holds the robot’s end effector, such as a gripper. The quill

moves up and down in the vertical plane and rotates around its vertical axis, but cannot tilt at an angle.

This unique design gives four-axis SCARAs a high degree of rigidity, which in turn allows them to move very fast and with high repeatability. In packaging applications, four-axis SCARAs excel at high-speed pick-and-place and other material-handling tasks.

Using Small Assembly Robots in Upstream Packaging Processes

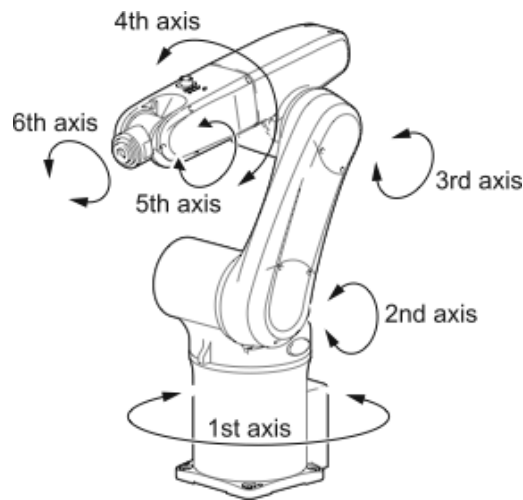

Six-axis articulated robot.

Six-axis articulated robots have two more joints than four-axis SCARAs and, as a result, more freedom of movement.

The first link swivels in the horizontal plane like a SCARA, while the second two links move in the vertical plane. In addition, six-axis articulated robots have a “forearm” and two “wrist” joints, which let them perform the same

types of movements that a human forearm and wrist are capable of.

The additional joints of six-axis articulated robots mean that they can pick up a part no matter how it is oriented off the horizontal plane, then insert it into a package that may require a special angle of approach. They can also perform many other operations that might otherwise call for the dexterity of a human operator.

Robot Automation Basics

Integrating a robot into a packaging line is an uncomplicated process.

The first step in automating a process with a robot is to determine whether the tasks to be performed will require a four-axis SCARA or six-axis articulated robot, and what type and size of end effector, or end-of-arm tooling (EOAT), is needed. For most upstream packaging applications, the end effector is a mechanical or magnetic gripper, or a vacuum pickup.

The next step is to calculate the payload capacity required, including the weight of the end effector, as well as the necessary reach, cycle time and repeatability. After a robot is selected, it needs to be integrated into the process.

Robots are usually mounted, either upright or inverted, in an enclosed automation workcell. The robot and any other associated equipment are bolted to the cell’s steel base. The upper walls of the cell are generally made of aluminum-framed, shatterproof clear plastic or see-through, metal-mesh screening.

Using Small Assembly Robots in Upstream Packaging Processes

This keeps operators from getting in the way of the robot, yet still allows them to observe the cell's activity.

As a safety precaution, opening the cell's access door automatically switches the robot off. In cases where the robot is not enclosed in a cell, light curtains or pressure-sensitive floor mats can provide the same type of automatic safety shutoff.

The robot's computerized controller, which contains the electronic circuits that run the robot, is usually situated on a platform underneath the cell.

Programming the robot is accomplished by means of either a teaching pendant—a handheld interface device that communicates with the controller—or by a computer. Most robot manufacturers offer user-friendly programming software that does not require specialized engineering skills.

The teaching pendant allows an operator to move the robot from one point to another and instruct it what to do at each location, thus “teaching” it the desired routine.

With available software, robots can also be programmed offline on a remote computer, saving development time. A virtual, simulated 3-D environment lets the user configure the robot and any peripheral devices without having to actually operate them.

Benefits of Small Assembly Robots in Packaging Operations

Compared with fixed automation, the single most important benefit of small assembly robots in packaging operations is their lower cost. Yet not only do robots have a lower initial cost—and thus a quicker ROI—their high degree of flexibility, small size and low maintenance requirements give them a lower overall cost as well.

Both fixed automation and robots can carry out packaging tasks more efficiently, more consistently and more cost-effectively than manual labor. Robots, however, have the added advantage of being able to fill in automation gaps—manually performed tasks which may still exist in an otherwise automated line, usually because a fixed-automation solution would be too expensive.

Unlike fixed automation, which must be specially designed for a particular process, robots are modular, off-the-shelf automation systems that can be adapted to a process with relative ease, greatly reducing the need for costly design engineering. In addition, robot workcells have a smaller footprint than fixed-automation machines, saving valuable

As off-the-shelf automation machines, robots provide a more flexible, lower-cost alternative to fixed automation.

Using Small Assembly Robots in Upstream Packaging Processes

factory floor space. And whenever necessary, a robot can be moved to an entirely different process and repurposed, reducing equipment investment.

Also unlike fixed automation, robots do not require expensive new tooling whenever the product changes. Most often, a relatively simple modification of the software program and, if necessary, a different end effector, are all that is needed. This can be particularly beneficial to manufacturers and contract packagers with small lot sizes requiring frequent, fast changeovers. Here, fixed automation is usually impractical or prohibitively expensive.

Furthermore, when equipped with a multifunctional gripper or automatic tool exchanger, a single robot can perform more than one function—such as loading and unloading a product, presenting the product for inspection and labeling, then inserting it into a packaging container—as well as handle multiple product sizes and shapes, all on the fly, without interrupting production. Vision systems and other options such as conveyor tracking can be easily installed, extending the robot's capabilities still further.

Another important advantage of robots is that their internal mechanisms are sealed inside protective coverings. This gives them much lower maintenance requirements than fixed-automation machines, whose motors and mechanical parts are usually left open and are thus subject to wear and damage from dirt and debris.

10 Things to Look for When Choosing a Robot

When choosing a robot, here are ten important things to look for:

1. Experience and reputation of the manufacturer:

Look for a manufacturer who has established itself as an industry leader and whose robots have stood the test of time.

2. Documented MTBF: Robots, which are often required to operate two or three shifts per day, every day of the year, must above all be reliable. Manufacturers who stand behind their robots' reliability will be happy to furnish documentation of their mean time between failures (MTBF).

3. High maximum allowable moment of inertia: Look for a robot with a high maximum allowable moment of inertia, the

Knowing what to look for is essential when comparing robots from different manufacturers.

Using Small Assembly Robots in Upstream Packaging Processes

measure of how much force it can exert. The higher the maximum allowable moment of inertia, the more easily the robot can lift and move a given size of payload, putting less strain on its motors and resulting in a longer working life.

4. Continuous-duty cycle time: When comparing robot cycle times, be sure to ask whether the figures given are for continuous duty or only shorter bursts of an hour or less. If the latter, the robot will have to operate at a slower speed in normal operation.

5. Compact, efficient robot design: A compact robot design with a small footprint makes integration easier and saves valuable factory floor space. In addition, designs with concealed air and electrical lines keep the lines from interfering with other equipment, as well as protecting them from wear and damage, thus reducing overall costs.

6. Robot controller features: Desirable features to look for in robot controllers include small size and weight; fast processing speed; modular expandability, to accommodate additional peripheral equipment without having to purchase a new controller; ease of integration with a vision system, PLC or other devices; and ease of servicing.

7. Affordable offline programming software: In general, most packaging applications are not difficult to program. Be sure the offline programming software being offered does not include expensive, advanced features that are unnecessary for your needs.

8. Low energy consumption: Ask about the robot's energy consumption. Efficiently designed, lightweight robot arms require less power, so their motors draw less electrical current. This can result in significant long-term cost-savings.

9. Safety codes: To protect employees and limit your company's liability, verify that the robot meets or exceeds all current safety codes.

10. Short training: Ask about the length of required training. Unnecessarily long training can result in excessive unproductive employee time and travel costs.

Using Small Assembly Robots in Upstream Packaging Processes

About DENSO Robotics

As one of the world's largest automotive parts manufacturers, DENSO Corporation has been a pioneer and industry leader in robot design and manufacturing since the 1960s. DENSO is also the world's largest user of small assembly robots, employing more than 17,000 robots in its own manufacturing facilities. Other companies use more than 42,000 additional DENSO robots worldwide.

DENSO Robotics offers a wide range of compact four-axis SCARA and five- and six-axis articulated robots for payloads of up to 20 kg, with reaches from 350 to 1,300 mm and repeatability to within ± 0.015 mm. Standard, Class 10 and Class 100 cleanroom, and IP65 dust- and mistproof models are available. ANSI and CE compliance enables global deployment. UL-listed models are available for both the U.S. and Canada.

Easy-to-use programming software, controllers and teaching pendants are also offered. The company's offline programming software, which features 3-D simulation, also allows remote monitoring of robot operations.

DENSO robots are used in packaging as well as a wide variety of other applications, such as assembly, dispensing, inspection, machining, machine tending, material handling, material removal, pick and place, test handling and ultrasonic welding.

Industries served include appliances, automotive, chemical, consumer products, disk drives, electronics, food and beverage, general manufacturing, machine tools, medical devices, pharmaceuticals, plastics and semiconductors.

For more information, visit the DENSO Robotics Web site at <http://www.densorobotics.com>.